

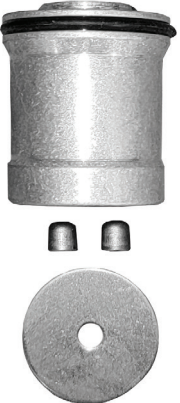

















Valve Body Kit

Instruction Manual

 <p>Manual Valve</p>	 <p>3-4 Accumulator Modification</p>	 <p>Outer Inner 3-4 Accumulator Spring Set</p>	 <p>Outer Inner Pressure Regulator Spring Set with "D" Washer</p>	
 <p>15#—W Throttle Valve & Spring(s)</p>	 <p>Heavy Inner Front Servo Spring</p>	 <p>1/4", 11/32", & 5/16" 3-4 Timing Valve Block Ball</p>	 <p>Heavy Lock-Up Valve Spring <i>*Constant-Pressure Kits Only</i></p>	
 <p>Blocker Spring & Long Boost Clip</p>	 <p>TV Washer & "E" Clip</p>	 <p>Dump Valve & Spring</p>	 <p>Lock Up Timing Spring</p>	 <p>Medium 1-2 Shift Spring</p>
 <p>Heavy 1-2 Shift Spring</p>	 <p>Medium 2-3 Shift Spring</p>	 <p>Heavy 2-3 Shift Spring</p>	 <p>Detent Bullet & Spring</p>	 <p>High-Pressure Relief Ball & Spring <i>*848TXR or 848TX Plate Kits Only</i></p>

Spring Measurements

Spring	Free Length	Wire Diameter	Coil Number	End Type
3-4 Accumulator Spring, Inner	2.360"	0.100"	12	Closed + Ground
3-4 Accumulator Spring, Outer	2.420"	0.130"	9.5	Closed + Ground
Pressure Regulator Spring, Inner	2.420"	0.040"	22.5	Closed
Pressure Regulator Spring, Outer	2.150"	0.072" <i>*0.075" in Constant-Pressure Kits</i>	12 <i>*9.75 in Constant-Pressure Kits</i>	Closed + Ground
Throttle Valve Spring, #15 <i>*Identical to Manual 1-2 Shift Spring</i>	1.270"	0.040"	9	Closed
Throttle Valve Spring, W	1.370"	0.050"	10.75	Closed + Ground
Inner Front Servo Spring, Heavy	2.180"	0.187"	4.25	Closed + Ground
Lock-Up Valve Spring, Heavy	1.560"	0.042"	10	Closed + Ground
Long Boost Clip Blocker Spring	0.620"	0.030"	20.5	Closed
Dump Valve Spring	0.700"	0.020" <i>*0.015" in Constant-Pressure Kits</i>	13.5 <i>*13.75 in Constant-Pressure Kits</i>	Closed
Lock-Up Timing Spring	1.500"	0.030"	9	Closed
1-2 Shift Spring, Medium <i>*Identical to High-Pressure Relief Spring</i>	0.915"	0.037"	7.5	Closed
1-2 Shift Spring, Heavy	0.100"	0.037"	9.75	Closed
2-3 Shift Spring, Medium	1.320"	0.047"	5.5	Closed
2-3 Shift Spring, Heavy	1.415"	0.051"	5.5	Closed + Ground
Detent Bullet Spring	0.800"	0.035"	11.75	Closed

Channel Casting Identification & Main/Lower Separator Plate Compatibility

Casting ID	Transmission	Main	Lower
129AA	Chrysler 48RE	848TM 848TCP 848TCPM 848TX	AO 22
648	Chrysler 47RE		22
218	Chrysler 47RE <i>*Early Style Only (1994 - 2000)</i>		91
848	Chrysler 47RH	848TMR 848TCPR 848TCPMR 848TXR	91
508/271	<i>*Do Not Use</i>	-	

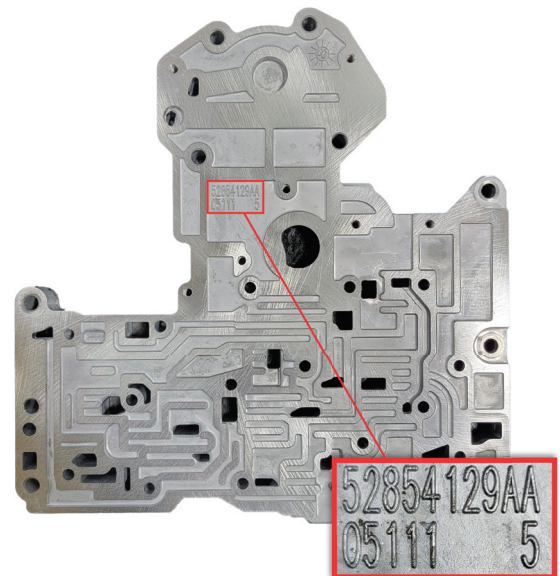

Channel Casting ID

Automatic-Shifting Valve Body Shift Spring Usage

Pressure	Year	Engine	Transmission	Shift Springs
Ranging	1994 - 1995	5.9L Cummins 12V	Chrysler 47RH	Medium 1-2 Medium 2-3
Ranging	1996 - 1998	5.9L Cummins 12V	Chrysler 47RE	Heavy 1-2 Heavy 2-3
Ranging	1998 - 1999	5.9L Cummins 24V	Chrysler 47RE	Stock 1-2 Heavy 2-3
Ranging	2000 - 2002	5.9L Cummins 24V	Chrysler 47RE	Stock 1-2 Stock 2-3
Ranging	2003 - 2004	5.9L Cummins CR	Chrysler 47RE Chrysler 48RE	Stock 1-2 Stock 2-3
Ranging	2005 - 2007	5.9L Cummins CR	Chrysler 48RE	W Throttle Valve Spring Stock 1-2 Stock 2-3
Constant	1994 - 2007	5.9L Cummins 12V - CR	Chrysler 47RH Chrysler 47RE Chrysler 48RE	Medium 1-2 Medium 2-3 <i>*Use Heavy shift springs when listed above.</i>

**All manual valve bodies will use the stock 2-3 shift spring and manual 1-2 shift spring. See last page for additional manual valve body kit instructions.*

A

Remove the limit valve spring and retainer. Discard the limit valve spring.

Reinstall the retainer [1] backward as to block the valve inward. This will result in an easier part throttle 3-2 downshift.

A plug in this location [2] will not affect operation.

Remove and discard the original Boost valve spring and retainer.

Install the **blocker spring [3]** and heavy duty retainer as shown. If this valve is left active damaging high pressure will result.

B

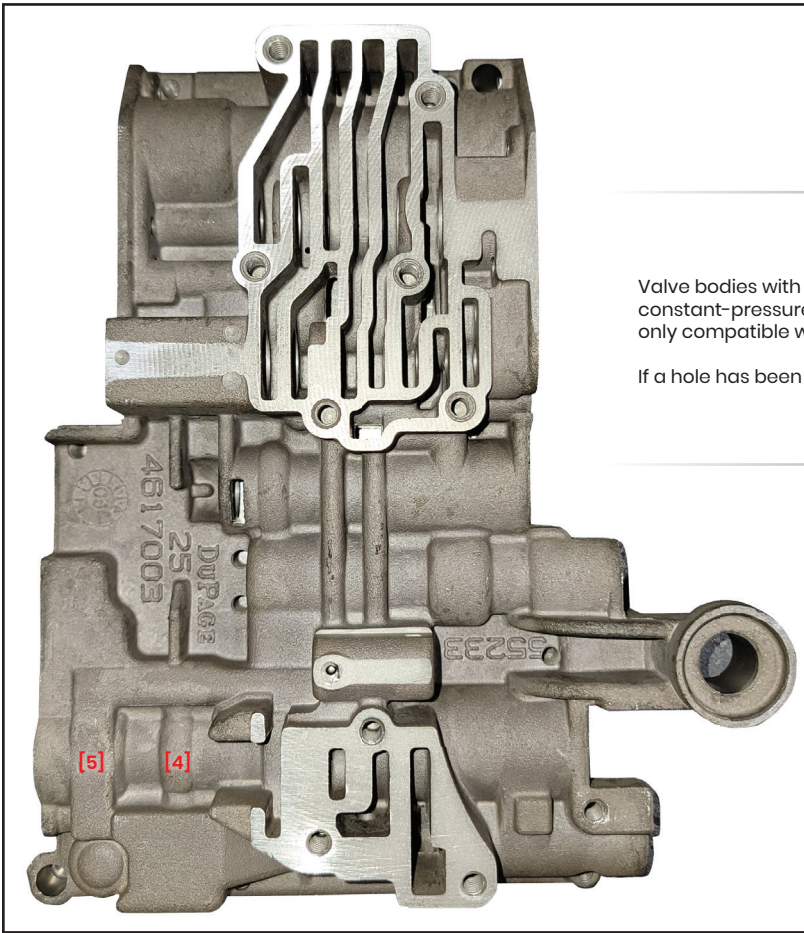

Valve bodies with a hole drilled in this location [4] are most likely an older Goerend constant-pressure valve body. Further identification may be required. This hole is only compatible with constant-pressure variations.

If a hole has been drilled in this location [5] do not use for Goerend valve body kits.

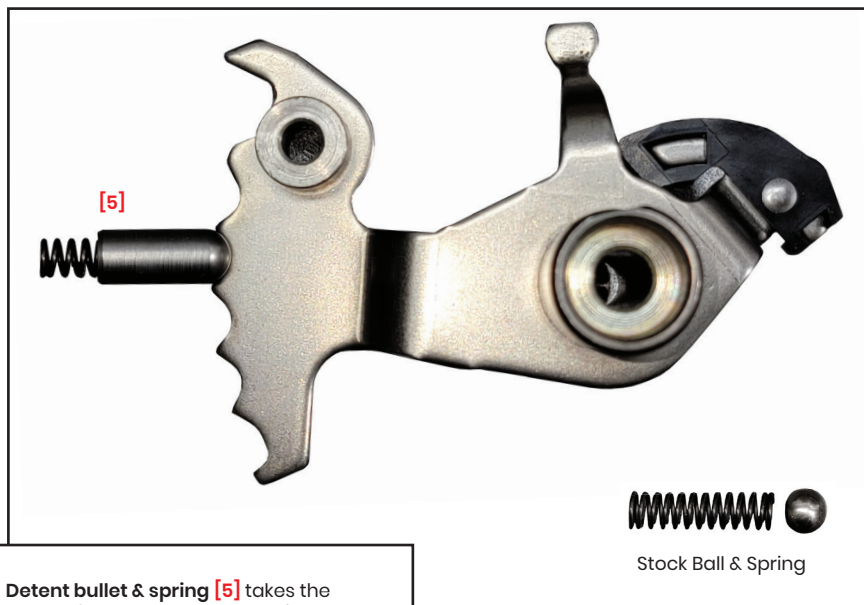

Detent bullet & spring [5] takes the place of the stock ball and spring.

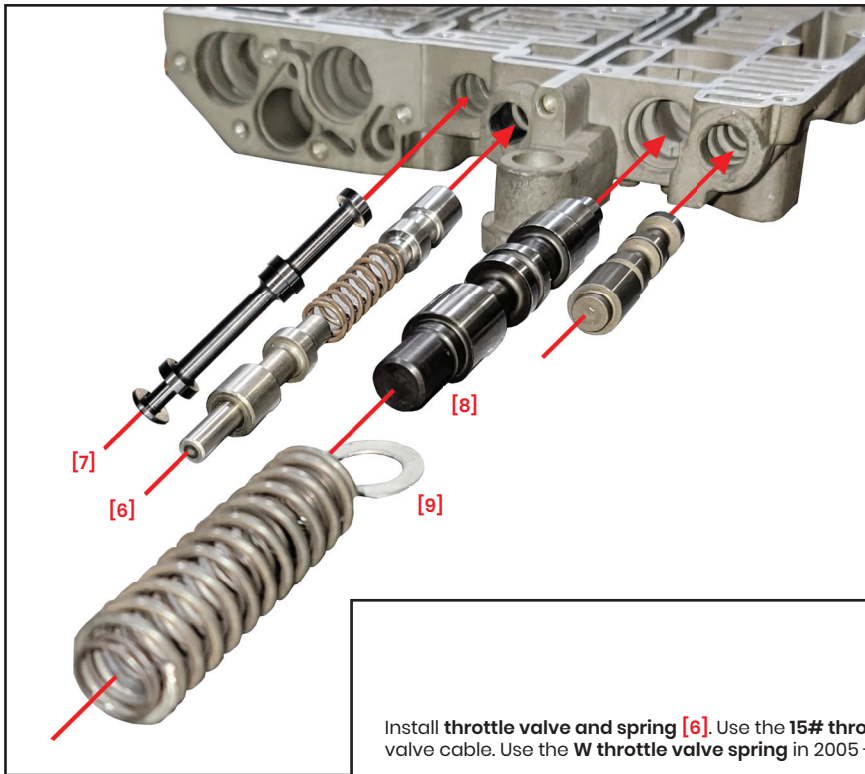

Install **throttle valve and spring** [6]. Use the **15# throttle valve spring** in 1994 - 2004 valve bodies with a throttle valve cable. Use the **W throttle valve spring** in 2005 - 2007 valve bodies with a TTVA motor.

**Using other valves or springs with a Goerend valve body kit will result in damaging high-pressure.*

Check bore for excessive wear, oversize if necessary. Oversize throttle valves, plungers, and sleeves available upon request.

Install **manual valve** [7] for increased lubrication flow when in park.

Install **pressure regulator valve** [8] into bore, followed by "**D**" **washer** [9]. The flat edge of the "**D**" will go towards the switch valve. Be sure the washer sits flat on the casting.

Install the inner spring. The coil-bound portion will cover the top of the valve.

Install the outer spring. Oversized pressure regulator valves available upon request.

F

Only use a stock style switch valve that has not been ground [10]. Stock valves have a step that is .010" smaller than the main land. This step is responsible for regulating torque converter charge pressure.

Do not use aftermarket switch valves with an enlarged step [11].

Stock and oversized steel switch valves are available upon request.

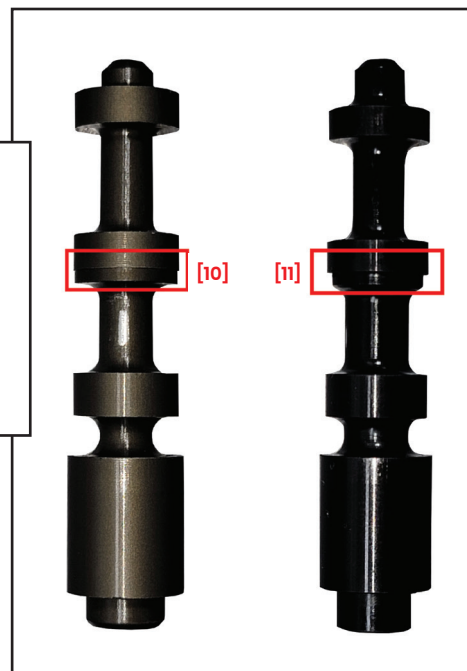

G

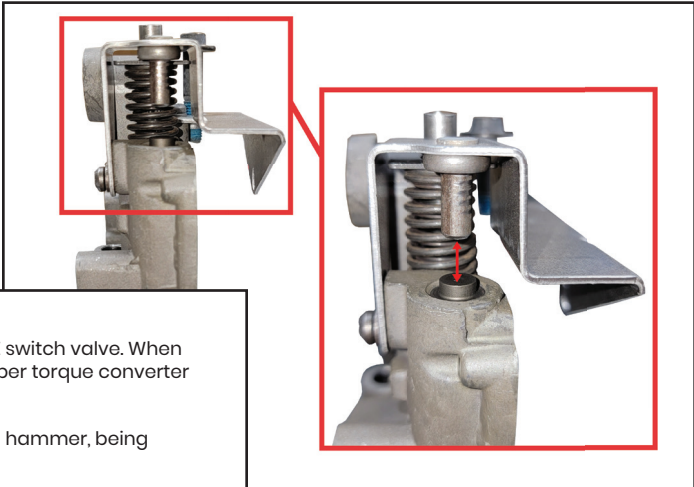

Set the gap between the switch valve and the stop to .300" - .320" with the OE switch valve. When using Goerend steel switch valves, set gap to .250" - .270". This will ensure proper torque converter lock-up engagement.

With the two main casting screws torqued to 40 lb-in., lightly tap bracket with hammer, being careful not to bend or damage the bracket, until desired gap is set.

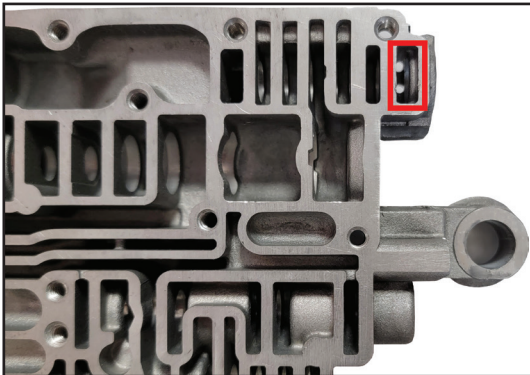

H

Goerend valve body kits are designed for a triple disc converter and no holes drilled at the switch valve.

If you are using a single disc converter, drill one at .080-.093"

If you want firmer lock up for high-horsepower or racing, drill 1-2 .080-.093" holes.

I

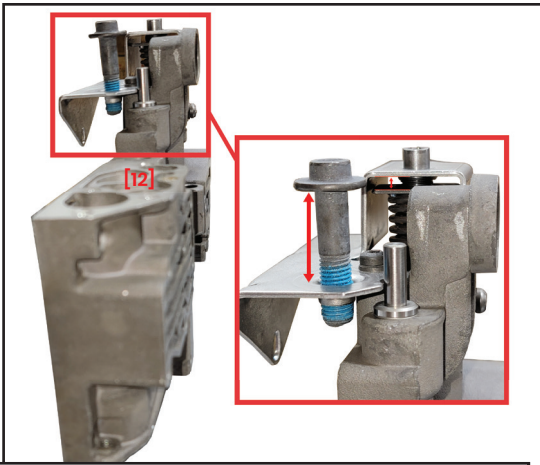

Set throttle valve lever stop to .900" or ECM codes may result [12].

The 2005 - 2007 W throttle valve bracket will have a turned down portion that holds the throttle valve sleeve down into the bore for use with the TTVA motor (not pictured). The W throttle valve bracket is available upon request.

The OE W throttle valve sleeve will measure approximately .440" in height. Do not use this height with the cable model bracket.

Throttle valve cable model sleeves will measure approximately .680" in height. Do not use this height with a W throttle valve bracket.

The oversized throttle valve sleeve will measure approximately .600" in height, and will work with either bracket.

Pressure Regulator Adjustment Clearances

Pressure	Spring	Clearance	PSI	Throttle
Ranging	15# Throttle Valve Spring <i>*Used all manual valve bodies and in 1994 - 2004 valve bodies with throttle valve cable.</i>	0	70	Idle
		0	170	WOT
		.100"	80	Idle
		.100"	180	WOT
	W Throttle Valve Spring <i>*Used in 2005 - 2007 valve bodies with TTVA motor.</i>	0	80	Idle
		0	180	WOT
		.075"	90	Idle
		.075"	190	WOT
Constant		.150"	100	Idle
		.150"	200	WOT
		0	150	

**Pressures are approximate and should be verified with a pressure gauge.*

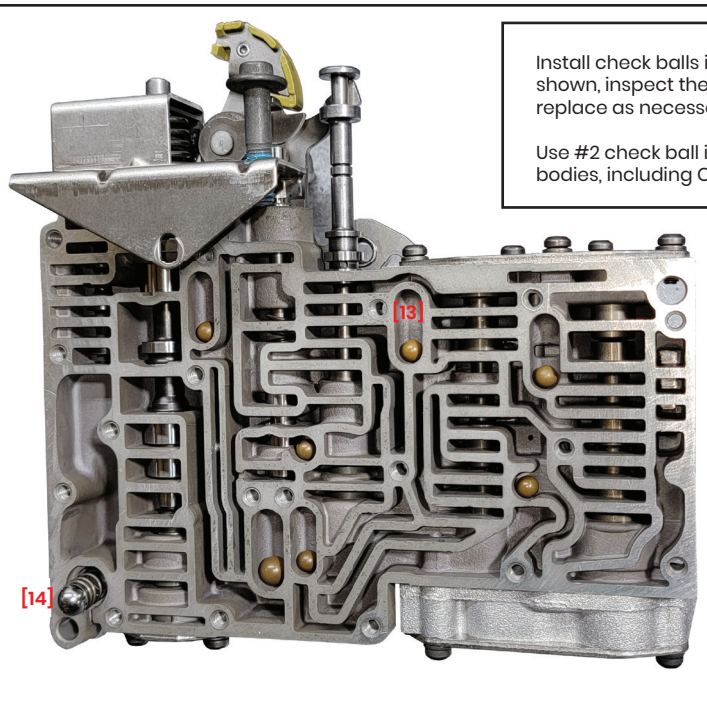

Install check balls in main casting as shown, inspect them for damage, replace as necessary.

Use #2 check ball in all Goerend valve bodies, including Chrysler 48RE [13].

J

K

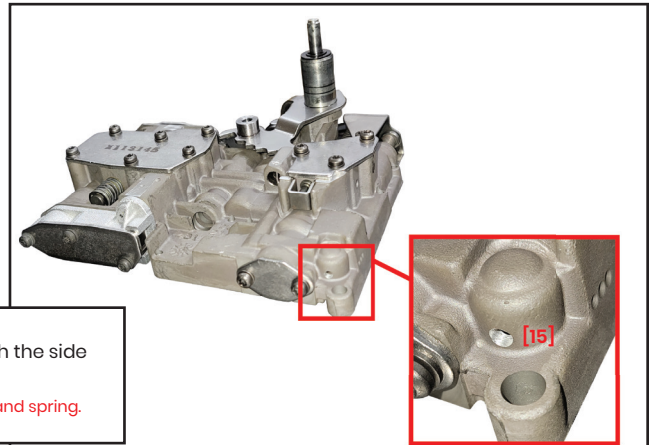

High-pressure relief ball & spring location [14]. Drill a .125" - .156" hole through the side of the casting into the pocket [15].

*848TX and 848TXR Kits Only. These plates must be used with a high pressure relief ball and spring.

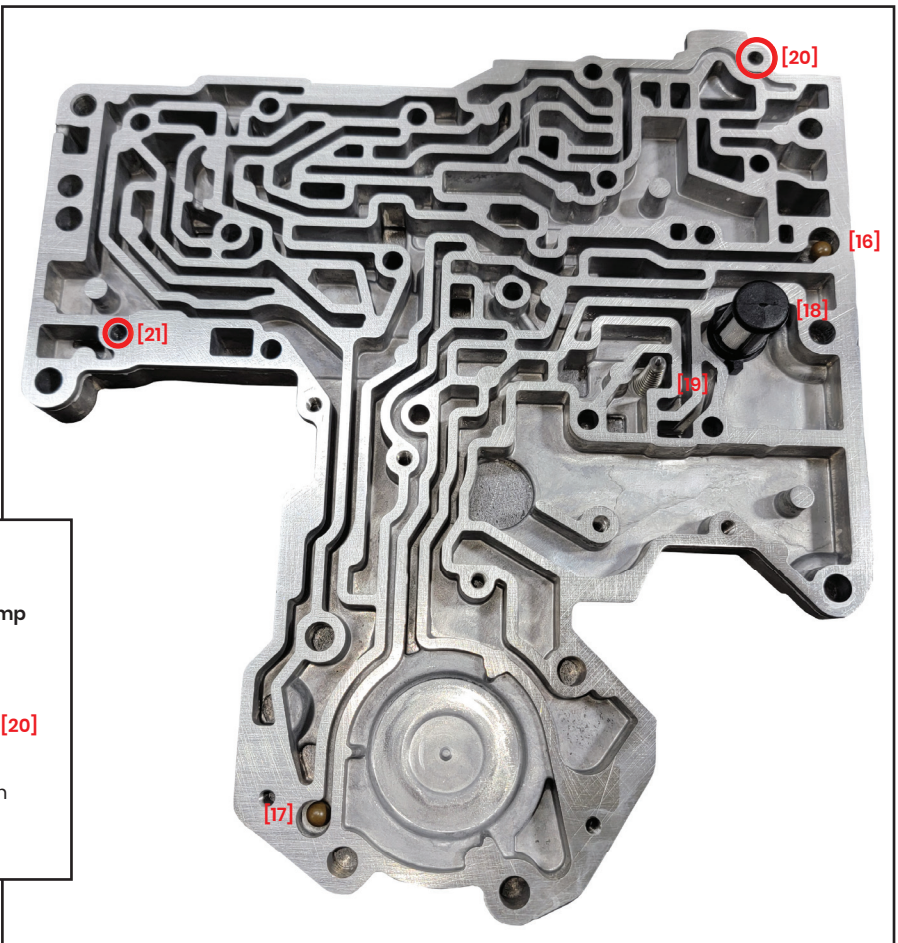

L

Install #7 check ball [16] and #9 check ball [17] into channel casting, along with the screen filter [18], dump valve and spring [19].

Install the main separator plate.

.190" alignment pins are recommended at locations [20] and [21] for proper alignment.

Be sure dump valve's point sticks out through hole in the separator plate.

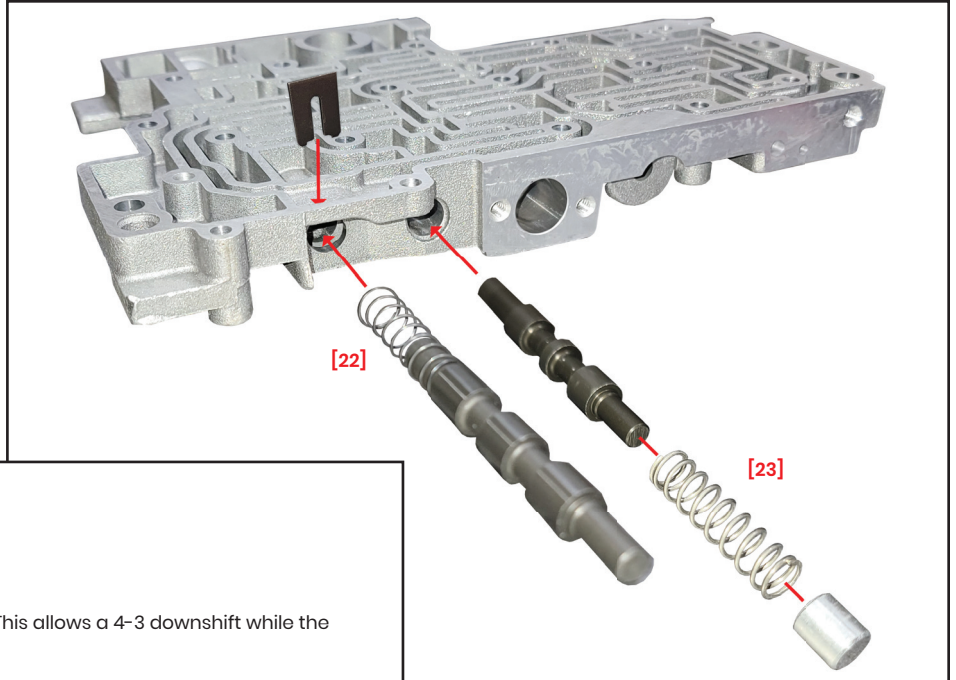

Lock-Up Timing Valve Installation

Remove and discard white OE spring.

Install new **lock-up timing spring [22]** as shown. This allows a 4-3 downshift while the torque converter is locked.

Heavy Lock-Up Valve Spring Installation

In constant-pressure kits only, install **heavy lock-up valve spring [23]** to prevent lock-up engagement when not commanded.

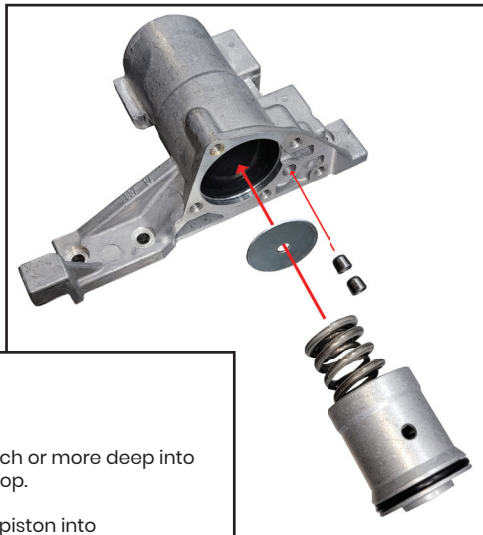

3-4 Accumulator Housing

With a punch install 1 cupped plug an inch or more deep into the hole, install the other flush with the top.

Install fender washer, dual springs, and piston into accumulator bore as shown. Use oil on o-ring seal.

Please note: If another VB Kit Modification has been done to this housing (holes drilled, holes plugged) this mod will not work.

1994 - 2002

2003+

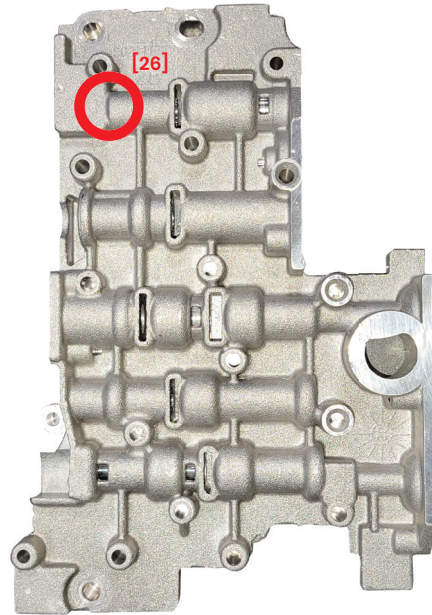
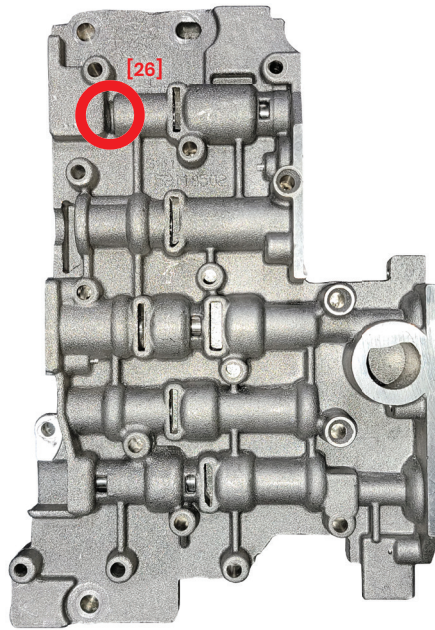

3-4 Timing Valve Blocking

There should be no holes drilled through the casting walls at locations [24] and [25].

Typical 1994 - 2002 castings are open at location [26]. Use the 1/4" ball to block the 3-4 timing valve out.

Typical 2003+ valve bodies are enclosed at location [26]. You may install the OE spring. If the vehicle has an exhaust brake or manual valve body, use the 5/16" or 11/32" ball that best blocks the valve out without protrusion. The small end of the valve may need to be ground to fit.

Blocking the 3-4 timing valve allows a 3-2 downshift with the converter locked.

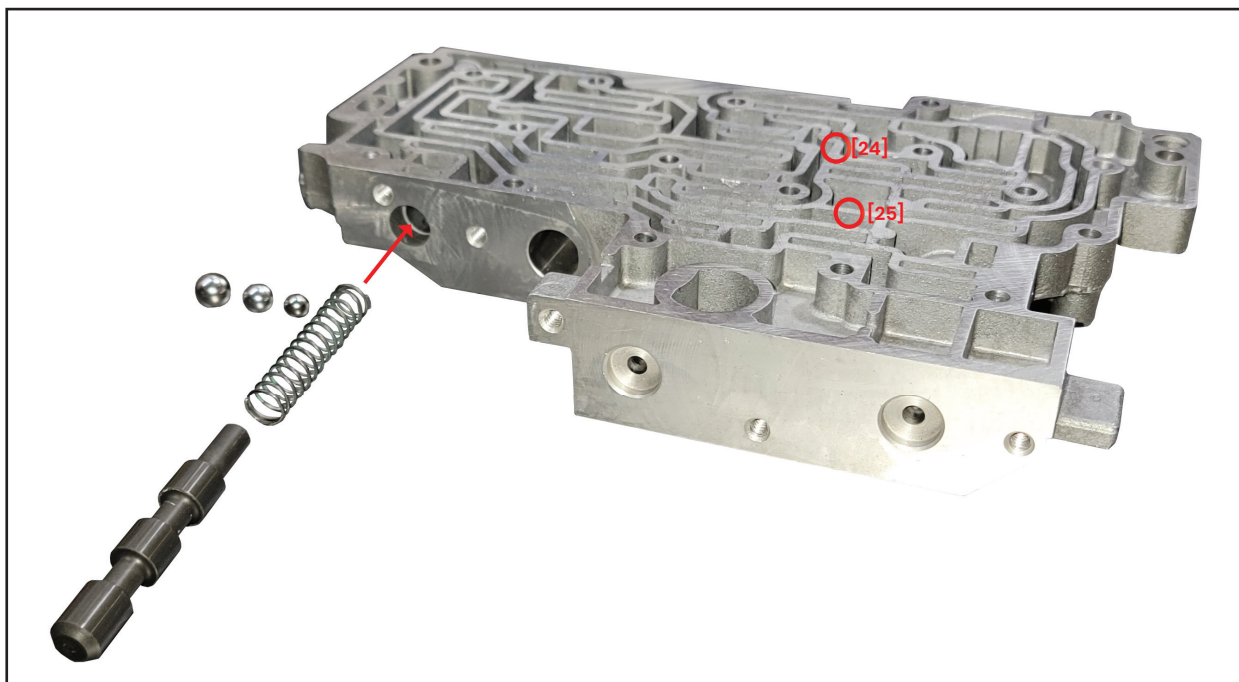

Goerend high-pressure valve bodies use a 3.8 intermediate (front) band lever in most applications, or a 4.2 lever in some racing applications. Do not use a 5.0 lever.

Remove the pin from the front of the transmission case and install a 3.8 intermediate (front) band lever.



There are no changes to the accumulator piston or spring, but these may be dislodged from the transmission case upon valve body removal.

Reinstall as shown [28].

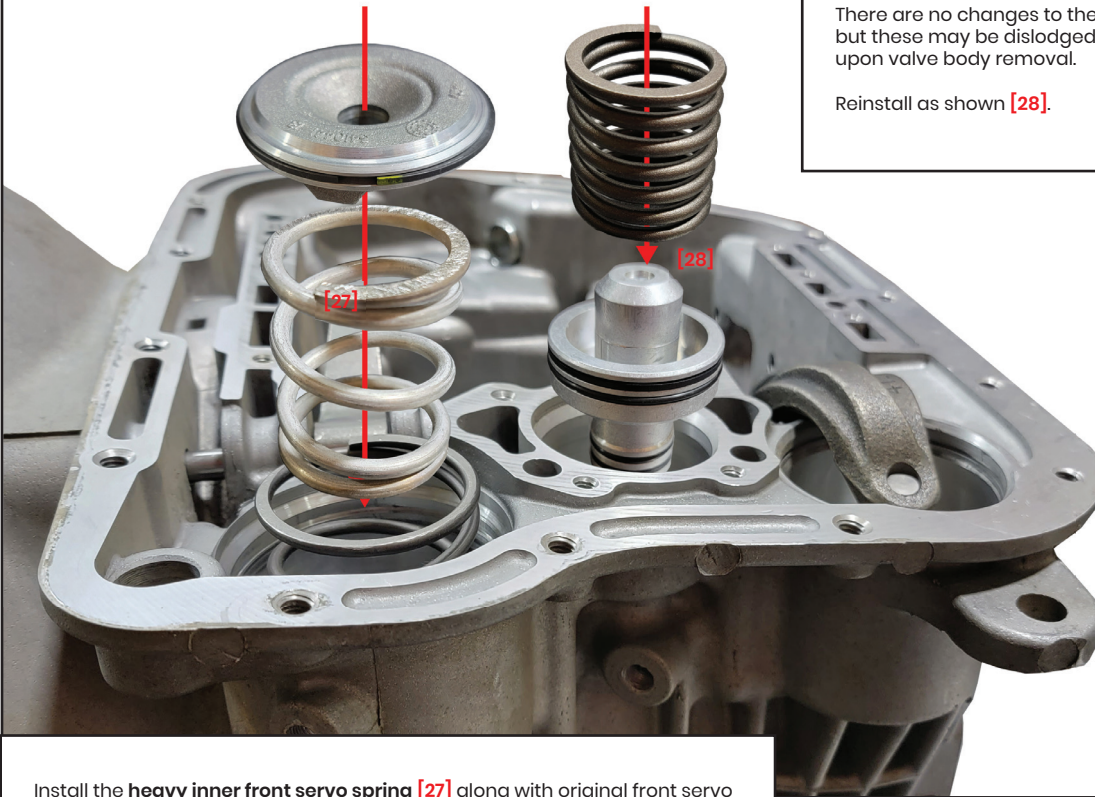

Install the **heavy inner front servo spring [27]** along with original front servo spring. A large C-clamp and socket or servo compressor tool can be used.

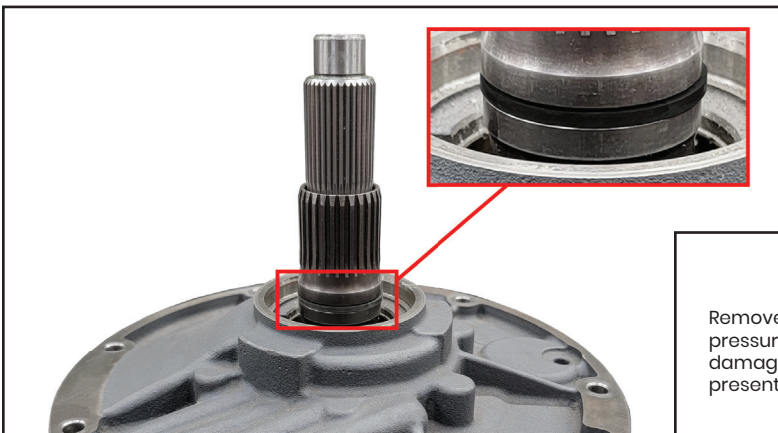

Remove the seal from the oil pump stator support when using a high-pressure valve body with a maximum line pressure above 180 PSI, or damage to the torque converter may result. This seal is typically only present in Chrysler 48RE transmissions.



Manual Valve Body Kit

Additional Instructions

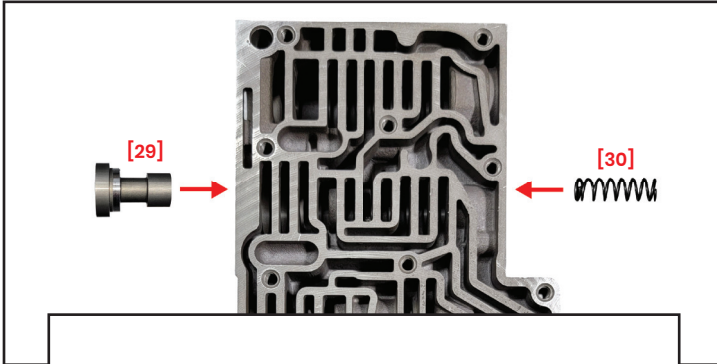

Install a manual 1-2 governor plug [29] and 15# throttle valve spring [30]. Reinstall OE 2-3 shift spring.

On Chrysler 47RH manual valve bodies, drill a .93" hole through the casting wall [31], connecting line to governor pressure.

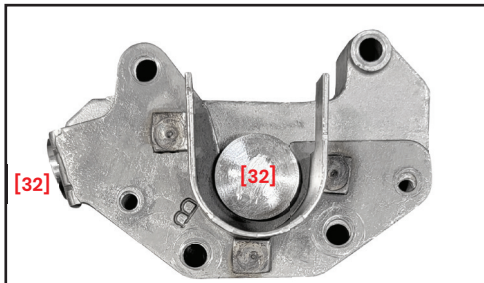
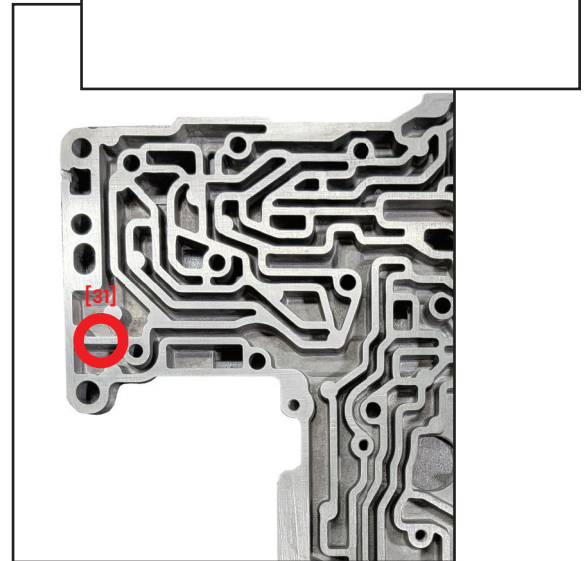

Goerend manual valve bodies come with aluminum plugs [32] in place of the governor solenoid and governor pressure/temperature sensor, since these electronics are not needed for the manual valve body to operate. Do not install a governor solenoid or sensor as this may cause the valve body to not function properly.

Constant-Pressure Manual Valve Body Information

Valve body line pressure is set on the with the pressure regulator adjustment screw. The external throttle valve lever does not change pressure or shift timing.

The external throttle lever position is used to tune the amount of overlap on the 2-3 shift.

An OE throttle valve cable or TTVA motor may be left active to vary the amount of shift overlap, or the throttle valve lever may be tied in a fixed position. With the throttle valve lever at 0% position (fully forward), you may experience shift underlap, otherwise known as RPM flare. In this case, increase the throttle valve lever position to 50 - 75% rearward, or until RPM flare is gone. If RPM flare remains with the throttle valve lever at 100%, the dual front servo spring set may need to be changed to a single medium "red" spring, available upon request.

Chrysler 47RH manual valve bodies can either be used with the hydraulic governor assembly intact and working, or fully removed. If removed, an RE-style overdrive piston support without governor tube holes must be used.

